

MARK NESBITT (LONDON)

RECOVERY OF ARCHAEOLOGICAL PLANT REMAINS AT KAMAN-KALEHÖYÜK

Kaman-Kalehöyük is a large settlement mound in central Turkey, currently being excavated by the Middle East Culture Center in Japan under the direction of Dr. Sachihiko Omura. I have previously reported on samples of charred plant remains recovered from the excavations at Kaman-Kalehöyük in 1990 and 1991. A relatively small number of samples were collected, and these were processed by hand, using a bucket. The results were highly promising (Nesbitt 1993), and in 1992 a flotation machine was built to allow processing of much larger numbers of samples. The flotation machine was operated for 10 days in 1992 and a month in 1993. In these two seasons 202 samples, each of about 45 litres, were floated. In some cases more than one sample was taken from a given deposit – for example, separately from the upper and lower parts of pits, so the number of discrete contexts is about 140.

Samples cover most of the excavated periods, with particularly good representation of the Medieval (period I), the late Iron Age (IIa) and the early Hittite and Assyrian colony periods (III). Preliminary analysis of the very substantial volume of material recovered is underway. A first glance confirms the impression of excellent preservation and great diversity present in the seed and charcoal remains, and a preliminary report will follow. At present, I am taking the opportunity to give a brief description of how sampling and flotation for charred plant remains have been done at Kaman-Kalehöyük. Although a number of papers describe how to build a flotation machine (Watson 1976; Williams 1973), and there are a number of papers concerned with the theory of sampling, little has been published on the practical side. This paper offers an opportunity to publish a good selection of photographs together with a brief explanatory text. A much more detailed (but less heavily illustrated) guide to flotation in semi-arid areas is to be published elsewhere by Delwen Samuel and myself.

Sampling

A standard sample size of about 50 liters is used. Trench supervisors are asked to fill four 14 liter buckets with soil for each sample, and to put two buckets of soil

into one sack. Samples therefore travel from the site to the flotation machine in two strong cloth sacks. Plate 1b shows sacks being lifted from the north slot trench up to a waiting tractor. The sacks are closed with string and wooden tags. These large, study tags do not get lost. Although waterproof marker pens are used for writing on the label, after the tag has been used it can be scrubbed clean.

The sample size was first chosen because about 40 liters has proven to be a suitable sample size at other Bronze Age and Iron Age sites. Preliminary examination of the samples indicates that 40–50 liters is an appropriate size here.

Understanding the taphonomy of seed assemblages is one of the fundamental aims of archaeobotany. In order to do this, it is necessary to sample by stratigraphic units so that separate depositional events do not become mixed. At Kaman-Kalehöyük the excavated contexts fall into three classes: pits, hearths and architectural units. Sampling decisions for pits and hearths are easy: all are sampled. In 1992 samples were separately taken from the top and the bottom of pits to check the degree of variation within a pit. In the case of houses and the areas between them, the excavated area at this site is simply too big to allow sampling of each stratigraphically defined area. Here I have focussed on a series of case studies of particular houses, where samples are taken above and between floors, inside and outside houses. Here even apparently rather amorphous “fill” deposits are rich in seeds.

Details about samples are recorded by trench supervisors on special forms (figure 4).

The Flotation Machine

The flotation machine is a standard Siraf type machine (Williams 1973), with slight modifications including a weir unit to hold the internal mesh in place (figs. 1, 2, 3). It is based on a large oil-drum, and cost about \$150 and one day of a welder's time to construct. The plumbing (based on one-inch pipes) is the most expensive part. The principle of operation is very simple. The upper part of the tank is lined with a 1 mm mesh (easily obtainable in Turkey in the form of window screen). A 1 mm and 0.3 mm sieve are suspended under the outlet spout.

Water is pumped into the machine. When the tank is nearly full, soil is added. It disaggregates in the water, the charred plant remains floating and thus flowing over the spout and into the sieves. This is the flot. The silt sinks through the internal mesh to the bottom of the tank and is discharged through the sludge outlet, while all other objects that sink but are larger than 1 mm are caught on the internal mesh. This is the heavy residue, and consists of a mixture of gravel, bone, very occasional charred seeds, and artefacts such as beads.

At Kaman-Kalehöyük, the machine is operated on a roofed 2.5 meter square concrete platform, with a buried pipe connecting to an electric pump that supplies water at a good pressure from a cistern. A settling tank in front of the sludge outlet catches the waste water and mud and allows the mud to settle. The waste water is then piped to the garden. There is plenty of space on the platform for two tables -one "dry" for note-taking, one "wet" for handling samples. Behind the platform is a large concrete yard where heavy residues can be spread out to dry. As the machine is at the excavation house rather than the site itself, samples are brought back by tractor.

Operation of the Flotation Machine

1. Soil samples arrive at the flotation machine (pl. 3a). Prior to flotation, the volume of the sample is measured in a calibrated bucket (pl. 3b). Although a standard four buckets (56 liters) is collected in the field, the volume in practice varies from about 35–50 liters. Measuring the volume will allow seed counts to be standardized to a per liter figure.

2. Prior to tipping soil into the flotation machine, the flexible 1 mm internal mesh has been placed inside (pl. 2b), resting on a heavy iron grid (pl. 2a). The mesh is pinned into place with clothes pegs, while the weir unit keeps it in place on the spout.

3. Soil is poured into the flotation machine (pl. 4a), keeping the bucket as close to the water as possible so as to avoid splashing. The bucketful of soil is then stirred by hand (pl. 4b, 5a) so as to encourage it to disaggregate. Charred plant remains float over the sieve (pl. 8a), while the heavy residue is collected by the internal mesh. The heavy residue is stirred until it is clean of mud. At this point, the second bucket of soil can be added. This process is repeated until all of the soil from that sample has been processed and no more seeds are floating to the surface.

4. The water is drained from the machine by opening the sludge valve wider. The heavy residue can then be washed with a hose (pl. 5b) before being lifted out (pl. 6a) and spread to dry in the sun (pl. 7a).

5. Meanwhile the flot is tipped (pl. 8b) from the sieves on cloth squares (now replaced by squares of net curtain, which allow it to dry much faster). The flots are hung up to dry in the shade (pl. 9b), and once dry can be transferred to self-sealing bags.

Processing of Heavy Residues

Once the heavy residues are dry, they are sieved through 5 mm and 1 mm meshes (pl. 7b). The above 5 mm fraction is then 100% sorted for bones, potsherds and artefacts. The bone and pottery is weighed so as to give per liter densities for all the sampled contexts, before being passed onto the relevant specialists. Sorting the under 5 mm fraction is much slower, and in general I aim to sort about 25% of each residue. Consultation with the zooarchaeologist, Hitomi Hongo, suggests that at this site the heavy residues are not very different in composition to the assemblages collected by 5 mm dry-sieving. However, the heavy residues have been an important source of eggshell, which is only erratically recovered by dry sieving. This is very frequent in medieval samples, and present but much less common in the late Iron Age deposits that immediately underlie the medieval levels. It remains to be seen whether the Iron Age eggshell is intrusive.

Acknowledgements

I thank John Letts for assisting with the flotation and photography, and Delwen Samuel for many discussions on how best to do flotation.

References

- Nesbitt, M. 1993. Ancient crop husbandry at Kaman-Kalehöyük: 1991 archaeobotanical report. *Bulletin of the Middle Eastern Culture Center in Japan* 7: 75–97.
- Watson, P.J. 1976. In pursuit of prehistoric subsistence: a comparative account of some contemporary flotation techniques. *Mid-Continental Journal of Archaeology* 1 (1): 77–100.
- Williams, D. 1973. Flotation at Siraf. *Antiquity* 47: 288–292.

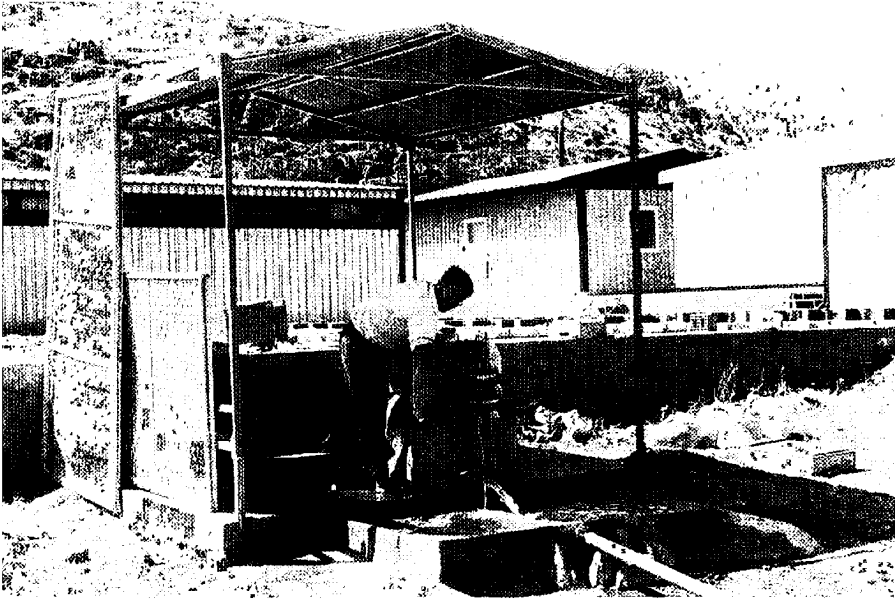

Plate 1a Flotation machine at Kaman-Kalchöyük. Note the settling tank in front.



Plate 1b Lifting flotation samples out of the north trench.

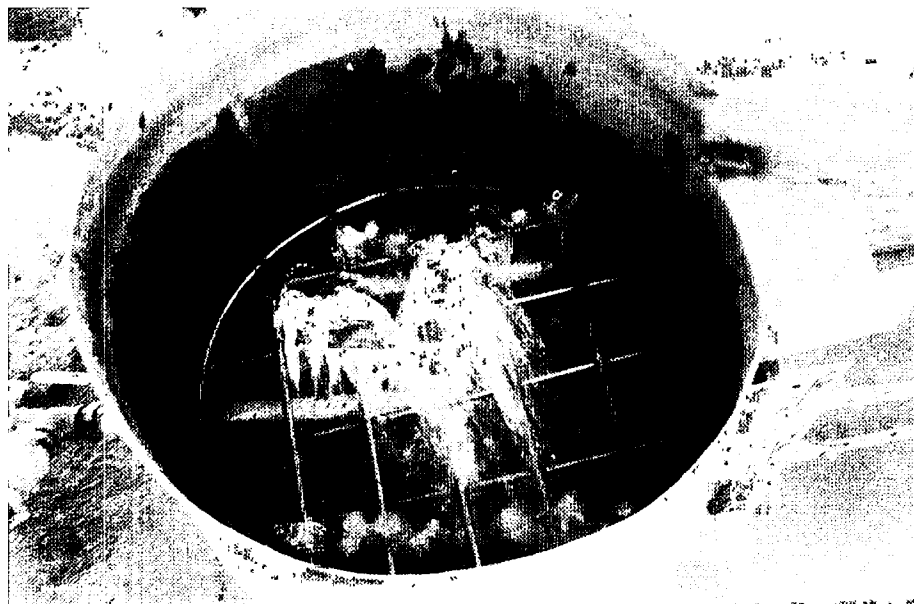

Plate 2a Support grid for the internal mesh.

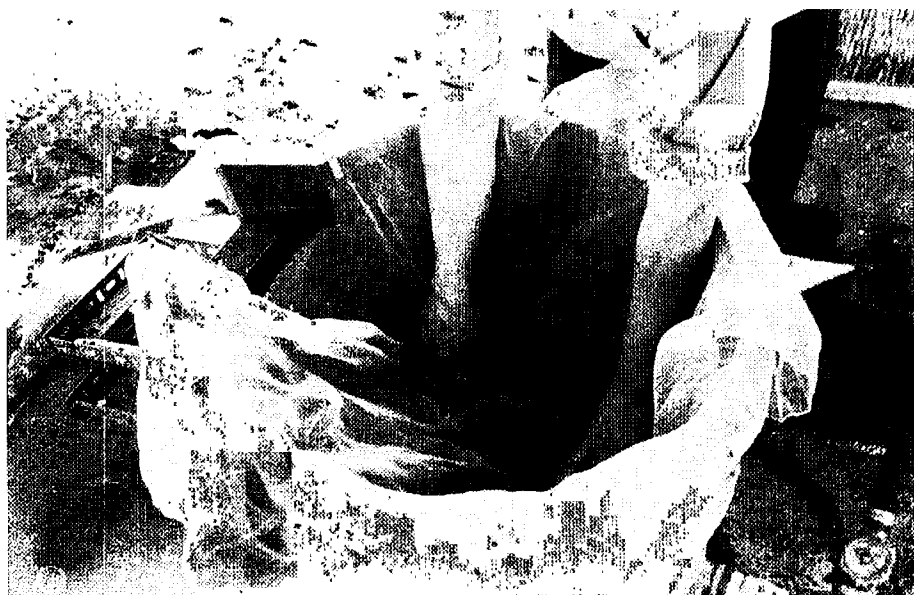

Plate 2b Inserting the internal mesh.



Plate 3a A flotation sample awaiting flotation.



Plate 3b Sample being poured from sack to measuring bucket.



Plate 4a Pouring soil into the flotation machine.

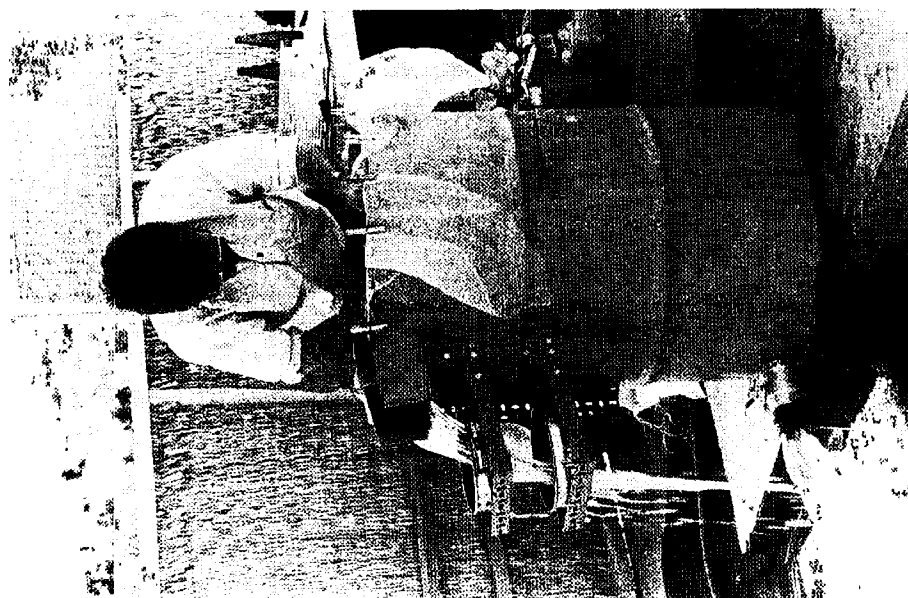

Plate 4b Working at the flotation machine.



Plate 5a Helping charred flot into the sieves.



Plate 5b Rinsing the heavy residue after emptying the machine.



Plate 6a Lifting out the heavy residue.

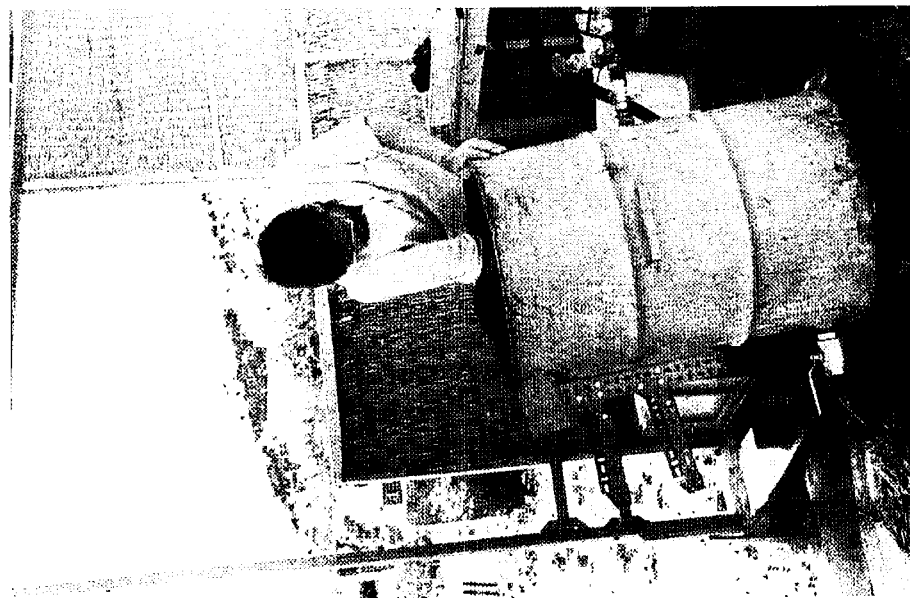

Plate 6b Cleaning out the machine.



Plate 7a Spreading out the heavy residue to dry.



Plate 7b Sieving the dry heavy residue.

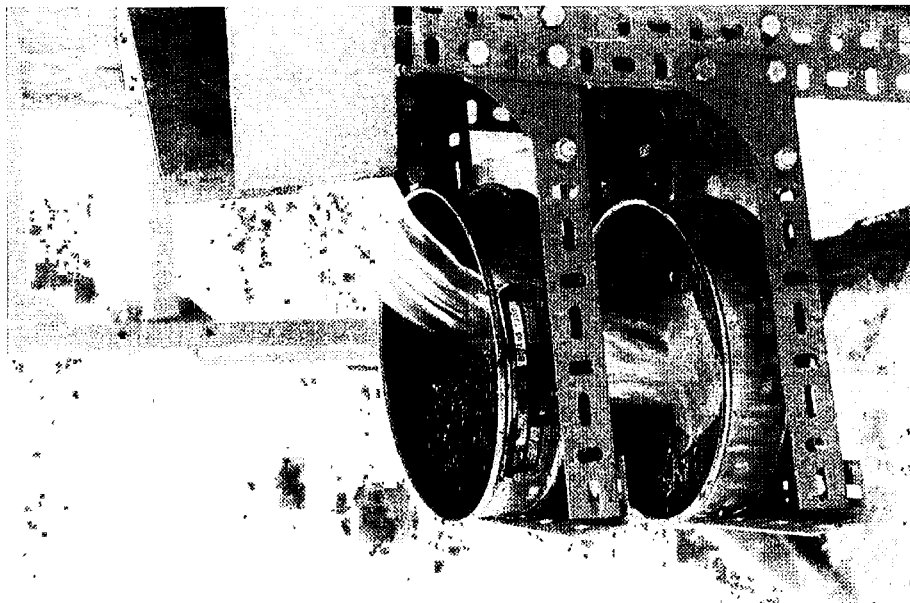

Plate 8a Flot flowing into the flot sieves.



Plate 8b Emptying flot from sieves to cloth squares.



Plate 9a Sorting bone and artefacts from a heavy residue.



Plate 9b Flot bags hanging up to dry.

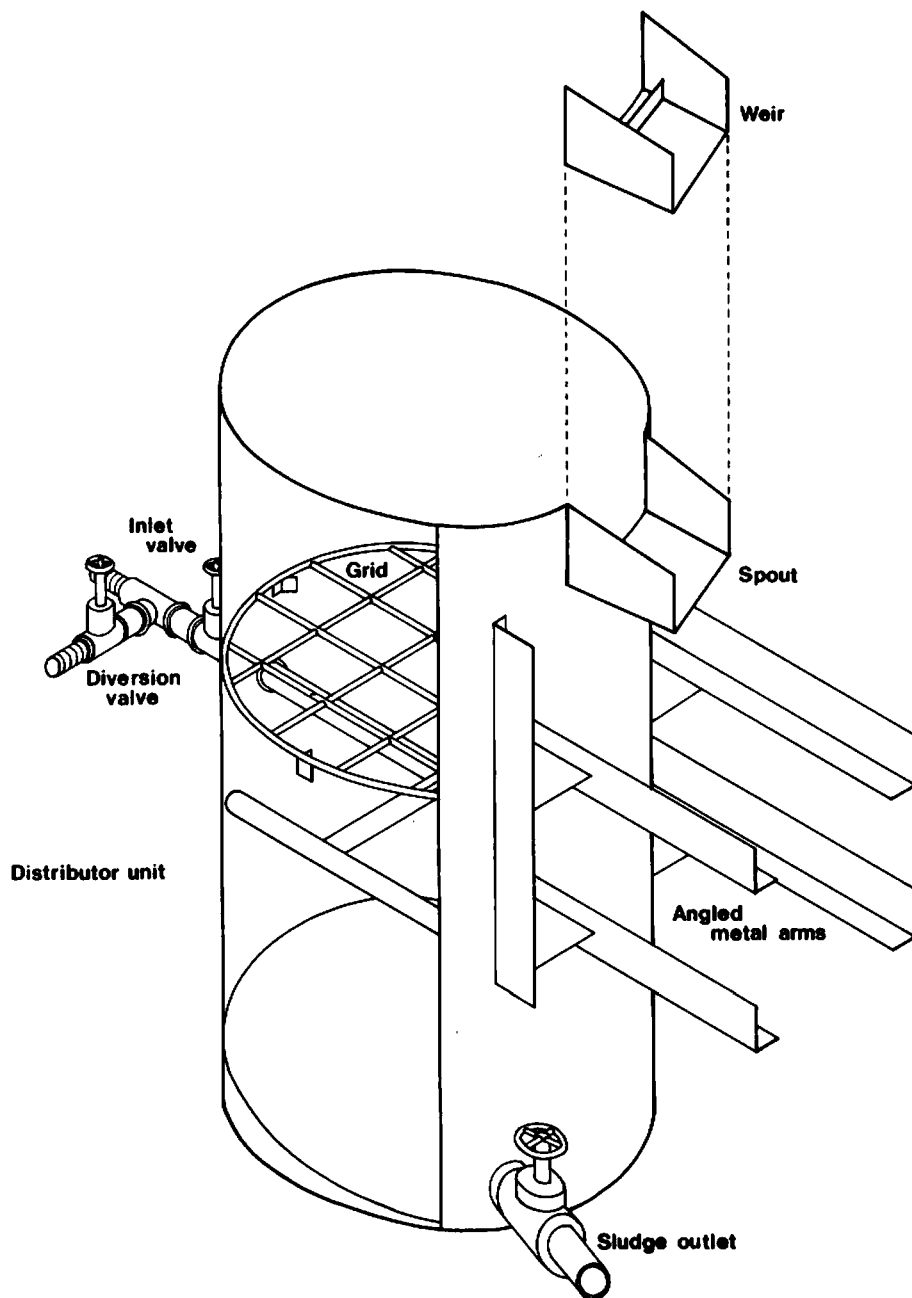

Figure 1 Isodimetric view of flotation machine.

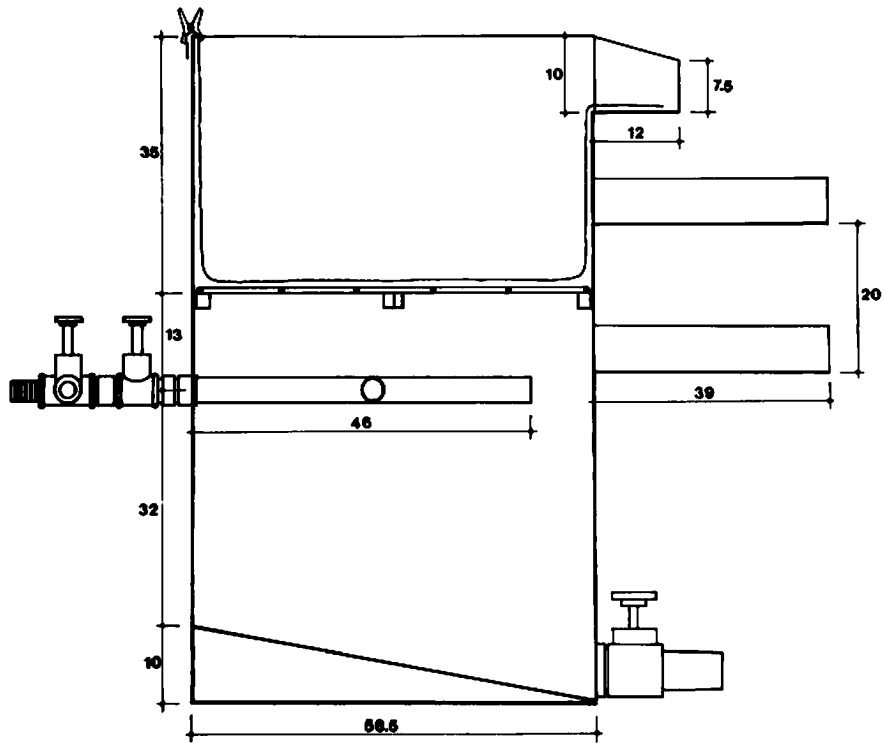

Figure 2 Section view of flotation machine. Measurements are in centimetres.

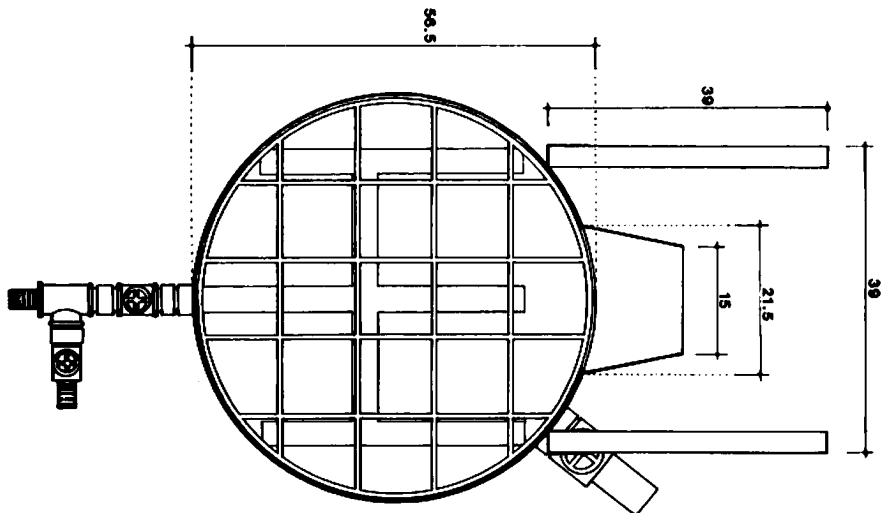

Figure 3 Plan view of flotation machine.

KAMAN-KALEHÖYÜK FLOTATION SAMPLE RECORD			
Kaman-Kalehöyük botanik örnekleme sistemi			
*SITE SAMPLE NO: <i>Höyük örneği</i>	*DATE COLLECTED: 93 - <i>Toplama tarihi</i>	FLOT NO: <i>Botanik örnekleme</i>	
*ARCHAEOLOGIST: <i>Arkeolog</i>	*SECTOR: KUZUY / GÜNEY <i>Açma</i>	*GRID:	
*BUILDING LEVEL: <i>Kat</i>	*PIT / HEARTH NUMBER: <i>Çukur / ocak numarası</i>	*ROOM NUMBER: <i>Oda numarası</i>	
*DESCRIPTION OF FEATURE & SOIL: <i>Toprağın özellikleri</i>			
*PROVISIONAL PERIOD: <i>Geçici tarihleme / dönem</i>			
I - Islamic IIa - Late Phrygian IIb - Phrygian IIc - Early Phrygian IId - Dark ages III - Hittite Empire III - Old Hittite III - Assyrian Colony III - M.B.A./E.B.A. transition III - Early Bronze Age			
POTTERY: <i>Seramik</i>		FINAL DATING: <i>Son tarihleme</i>	
FLOTATION	NAME:	DATE:	
VOLUME PROCESSED:	buckets =	litres	
FLOTATION COMMENTS:			
< 5mm HEAVY RESIDUE: SORTED: YES / NO ___ %			
EGGSHELL: YES / NO FISH: YES / NO			
CARBON ASSESSMENT:			
SEEDS:	NONE	POOR	MEDIUM RICH

Figure 4 Record sheet for flotation samples.

Offprint

Essays on
Ancient Anatolia and
its Surrounding Civilizations

Edited by

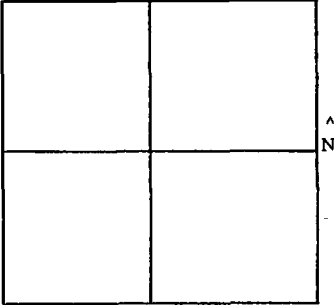
H. I. H. Prince Takahito Mikasa

1995

Harrassowitz Verlag · Wiesbaden
